

Scambiatori acqua-olio serie MG81

Water-oil heat exchangers series MG81

Con circuito acqua ispezionabile a uno-due-quattro passaggi. One-two-four ways controllable water circuit

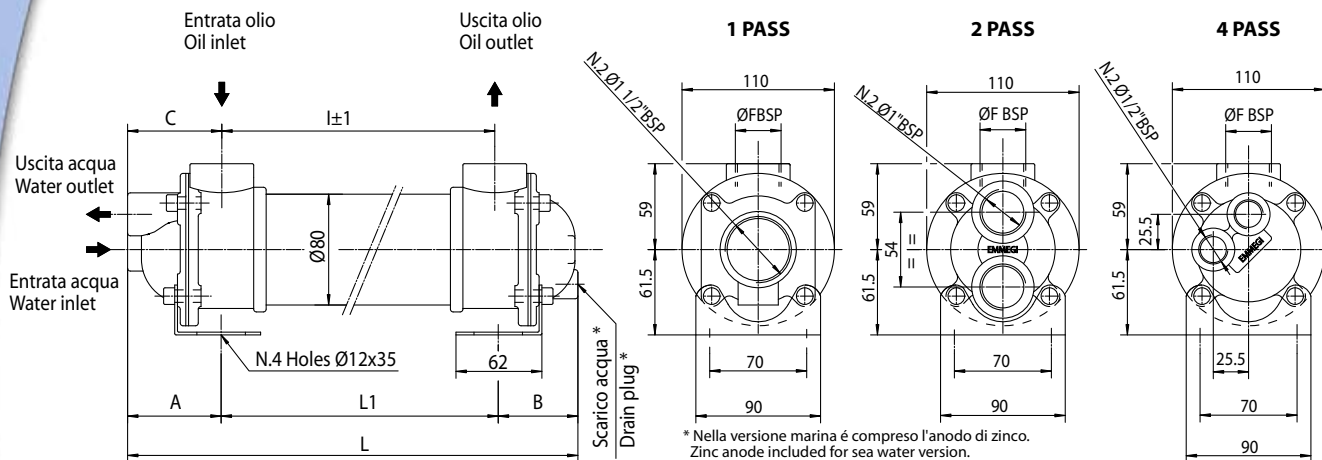

Le dimensioni e le caratteristiche tecniche non sono impegnative. Over-all dimension and technical characteristics are not binding.

TIPO TYPE	TUBI TUBES	PIASTRA TUBIERA TUBES SHEET	DEFLETTORI BAFFLES	FONDI COVERS	MANTELLO SHELL	GUARNIZIONI SEALS
STANDARD	CuDHP	CuZn40	CuZn37	CuZn40	Fe510.2	Rubber-cork
SEA WATER	CuNi10Mn1Fe	CuZn40	CuZn37	CuZn40	Fe510.2	Rubber-cork

TIPO TYPE	PORTATA OLIO OIL FLOW (lt/min)	HP DISPERSI CON OLIO HP DISSIPATED WITH OIL =55°C H2O=20°C	CAPACITA' CONTENTS (lt)	Kg	Dimensioni - Over all dimension																				
					1 Pass							2 Pass							4 Pass						
					ØF	A	B	C	I	L	L1	ØF	A	B	C	I	L	L1	ØF	A	B	C	I	L	L1
MG 81-310..	50-120	11-18	1.2	5.7	1 1/2"	90	90	92	310	494	314	1 1/2"	72	64	74	310	450	314	1 1/2"	72	64	74	310	450	314
MG 81-385..	50-120	13-21	1.4	6	1 1/2"	90	90	92	385	569	389	1 1/2"	72	64	74	385	525	389	1 1/2"	72	64	74	385	525	389
MG 81-560..	60-150	16-25	2	7.5	1 1/2"	90	90	92	560	744	564	1 1/2"	72	64	74	560	700	564	1 1/2"	72	64	74	560	700	564
MG 81-715..	75-180	20-29	2.4	8	1 1/2"	90	90	92	715	899	719	1 1/2"	72	64	74	715	855	719	1 1/2"	72	64	74	715	855	719
MG 81-870..	75-180	24-34	2.9	10	1 1/2"	90	90	92	870	1054	874	1 1/2"	72	64	74	870	1010	874	1 1/2"	72	64	74	870	1010	874
MG 81-1155..	75-180	29-40	3.8	13.5	1 1/2"	90	90	92	1155	1339	1159	1 1/2"	72	64	74	1155	1295	1159	1 1/2"	72	64	74	1155	1295	1159

DIAGRAMMA RENDIMENTO

Alla portata massima e minima indicata in tabella

PERFORMANCE DIAGRAM

At the maximum and minimum flow stated in schedule

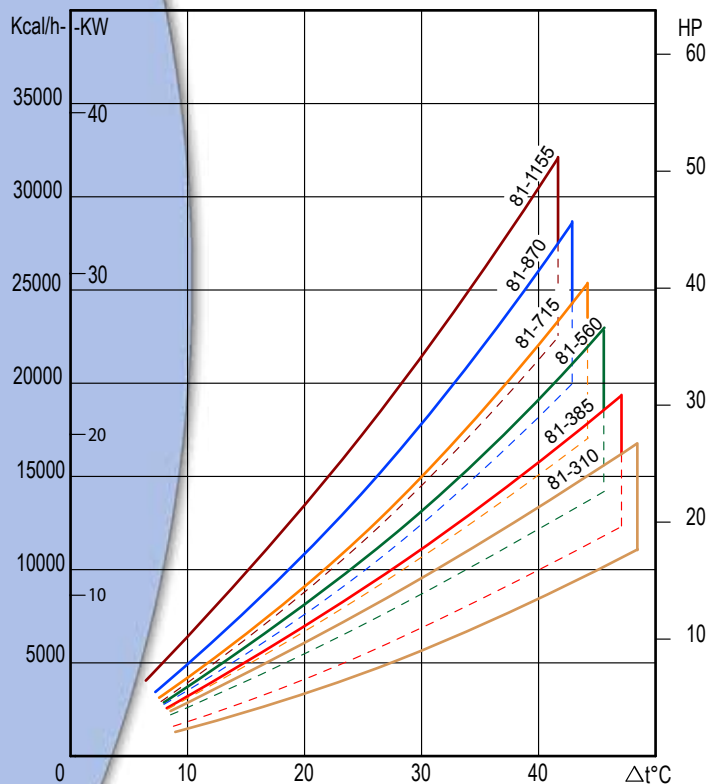

FATTORE DI CORREZIONE (F)-PERDITE DI CARICO CORRECTION FACTOR (F)-PRESSURE DROP

CST	10	15	20	30	40	50	60	80	100	200	300
F	0.5	0.65	0.77	1	1.2	1.4	1.6	1.9	2.1	3.3	4.3

PERDITE DI CARICO (32 cst) PRESSURE DROP (32 cst)

