

## SPEED REDUCER GEARBOX SAE A/B

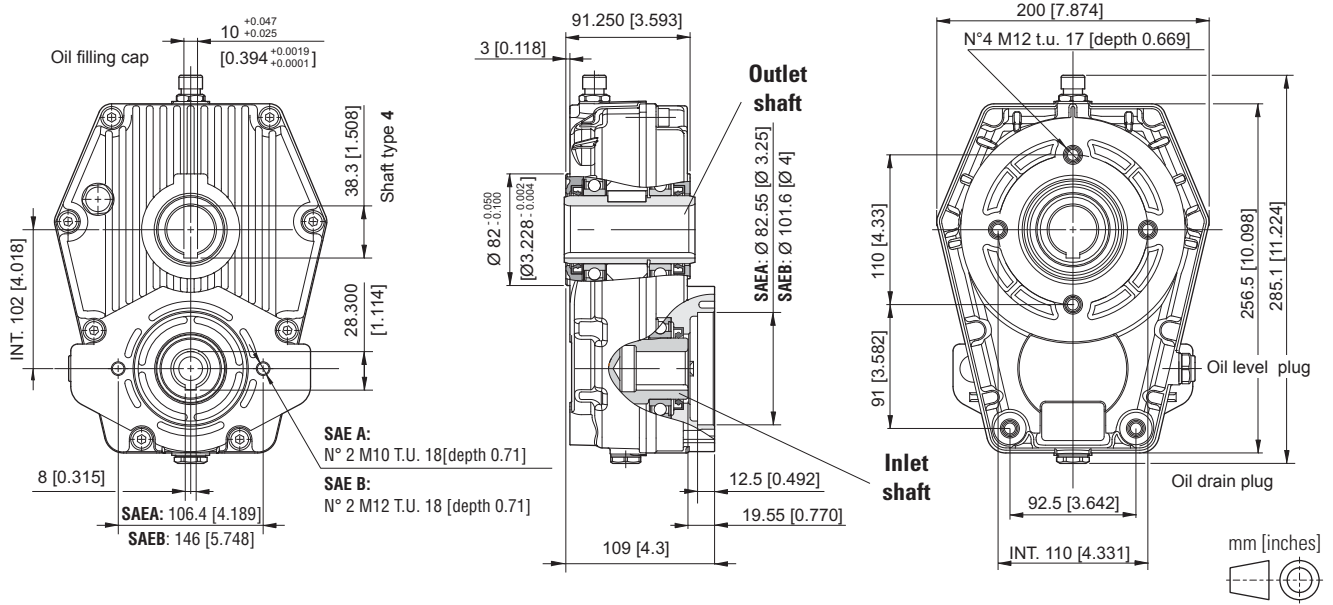

### Shaft

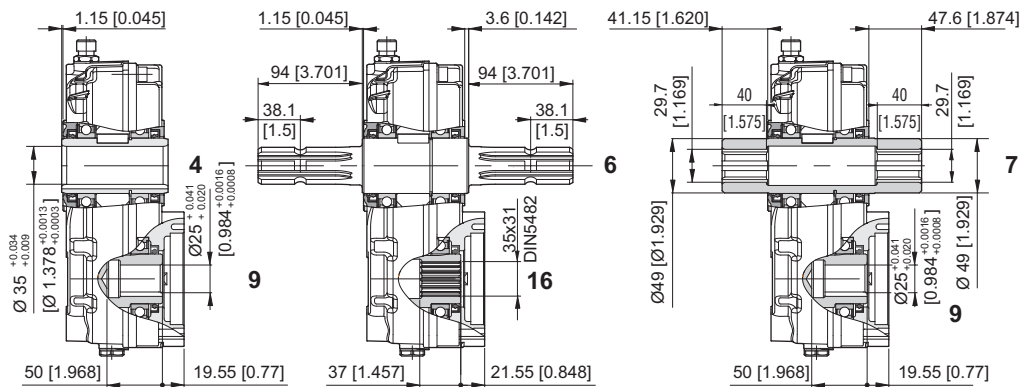

### Mounting positions

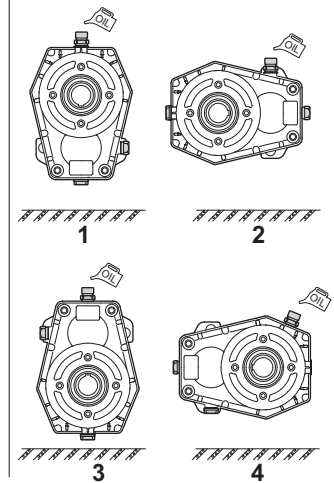

## ORDERING CODE

RD52/SAE\* - \* -1/ \*\*\* - \*\* - \*

**RD52/SAE A** = Speed reducers (aluminium body)  
**RD52/SAE B** = Speed reducers (aluminium body)

### Output shaft

**4** = Female Ø 35 mm  
**6** = Male/Male 1" 3/8 DIN 9611  
**7** = Female/Female 1" 3/8 DIN 9611

### Transmission ratio

**0,66** = 1.5 : 1  
**0,50** = 2.0 : 1  
**0,38** = 2.6 : 1  
**0,33** = 3.0 : 1  
**0,29** = 3.4 : 1  
**0,26** = 3.8 : 1

### Mounting positions

**1 / 2 / 3 / 4**

### Input shaft

**9** = Female Ø 25  
**16** = Female Z18 DIN 5482 (35x31)

Coupling for pump to be required to our sales department.

## TECHNICAL DATA

Transmission ratio	Maximum torque Nm [lbf-ft]		Weight kg [lb]
	200 rpm		
	C1*	C2*	
0.66	608 [448]	320 [236]	9,5 [20.9]
0.50	460 [339]	242 [178]	7,9 [17.4]
0.38	397 [293]	209 [154]	8,3 [18.3]
0.33	359 [265]	189 [139]	8,2 [18.1]
0.29	298 [220]	157 [116]	8,8 [19.4]
0.26	261 [193]	137 [101]	7,9 [17.4]

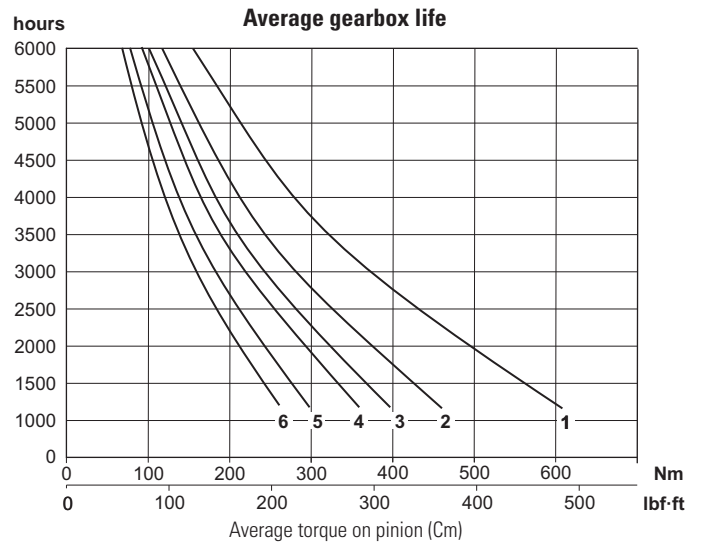

\* Maximum torque on pump:  
C1= maximum starting torque; C2= maximum torque for continuous duty.

Mounting positions	Oil liters [US gallon]
1	0.34 [0.09]
2	0.80 [0.21]
3	0.52 [0.14]
4	0.75 [0.20]

Output rpm	Input (transmission ratio)						
	0.66	0.50	0.38	0.33	0.29	0.26	
200	curve 1	2	3	4	5	6	
	rpm	300	400	500	600	680	760

## SPARE PARTS

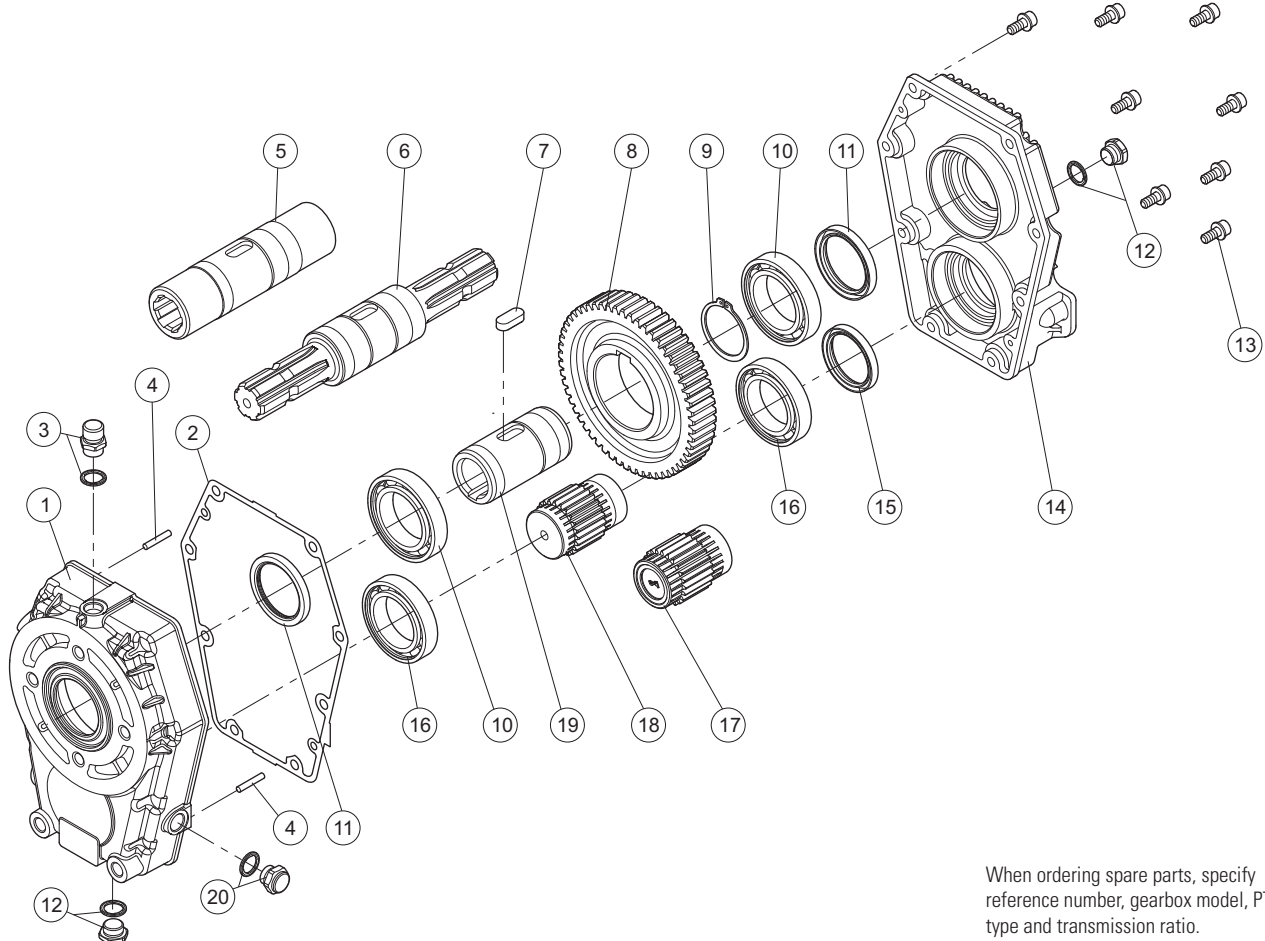

When ordering spare parts, specify reference number, gearbox model, PTO type and transmission ratio.